



Robust Optimization of Automotive Software Architecture

Presented By:
Indika Meedeniya
Principle Coordinating Supervisor:
Dr. Irene Moser
Coordinating Supervisor:
Dr. Lars Grunske
Associate Supervisors:
Prof. Jun Han
Dr. Antony Tang



Role of Software in Automotive Systems

- Safety airbag
- Anti-lock brake system
- Adaptive cruise control
- Electronic stability control
- Power assisted steering
- X-by wire
- Navigation
- Intelligent Parking Assistance
- Multimedia – onboard entertainment
- ...

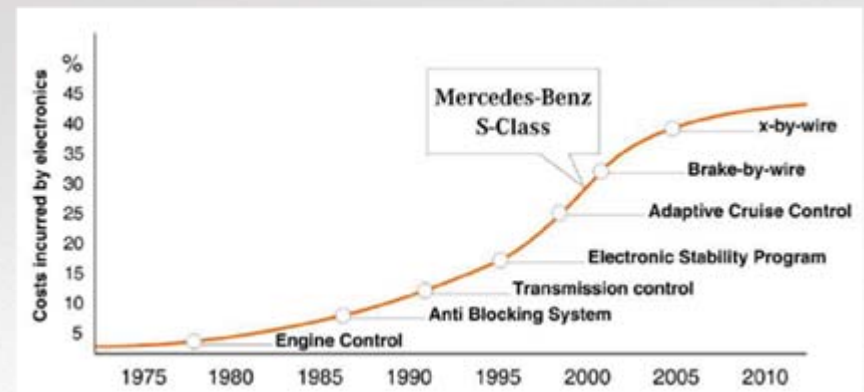



Quality of Software

Dependability and other quality requirements are crucial

- Safety
- Reliability
- Availability
- Cost
- Maintainability
- Performance / Response Time
- Energy consumption
- ...



Quality Evaluation

- Testing is insufficient !
 - Failure rates under 10^{-6} h^{-1}
 - Safety requirements
 - Intermittent failures
 - Race conditions
- Mathematical, statistical Models are often used to abstract the quality attributes
 - Software component models
 - Tasks and Scheduling
 - ECU execution models
 - Communication
 - Environment/User Models



Architecture Optimization

- Deployment
- Redundancy allocation
- Hardware/Software Component selection
- Hardware/Software Parameter configuration
- Scheduling
- ...



Architecture Design Challenge - I

- Conflicting nature
- Trade-offs are necessary in the system design
- Huge Design Space
 - Eg. Deployment of Software Comps to ECUs can be 1000^{100} .
- How to Find best possible trade offs?

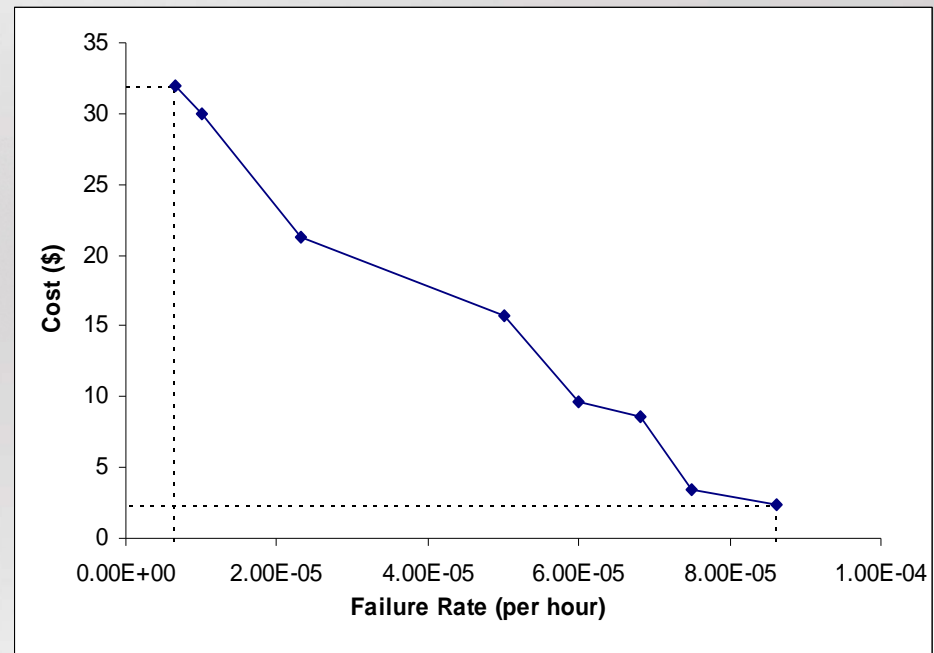

Trade-offs in design objectives



Architecture Design Challenge II

- The models are based on point estimates.
 - Estimates are subjected to variations and impact of this variation is significant
 - Factor of uncertainty is there
 - Manufacturer (OEM)'s estimation may not capture exact operational characteristics of the component
 - In automotive domain, usage of the system, environment etc. have a large variance
- How to find alternatives that can withstand uncertainties?

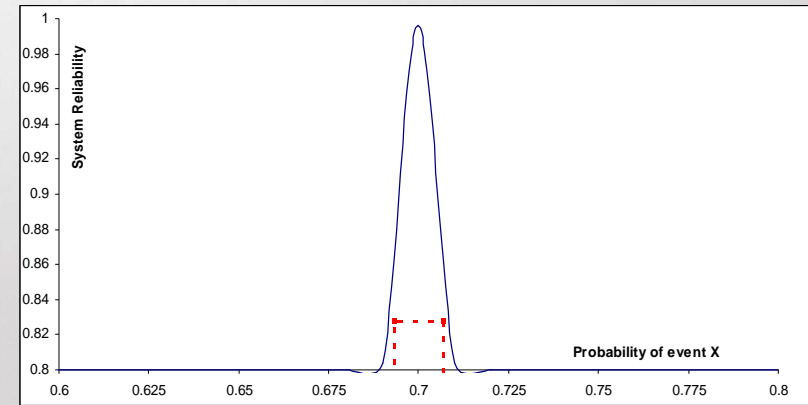

Solution 1

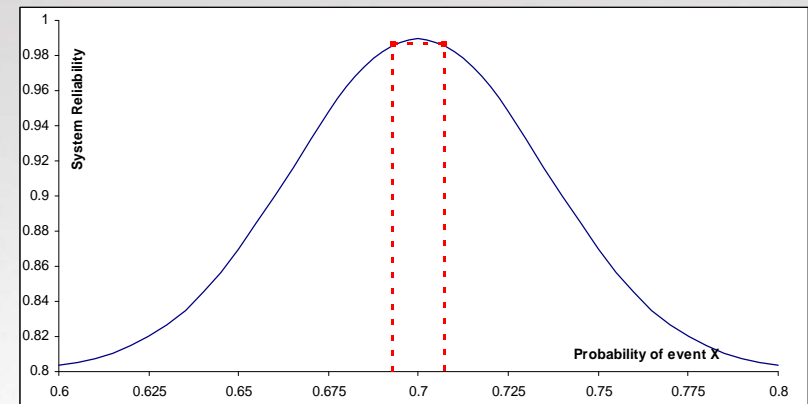

Solution 2



Robust Architecture Optimization Approach

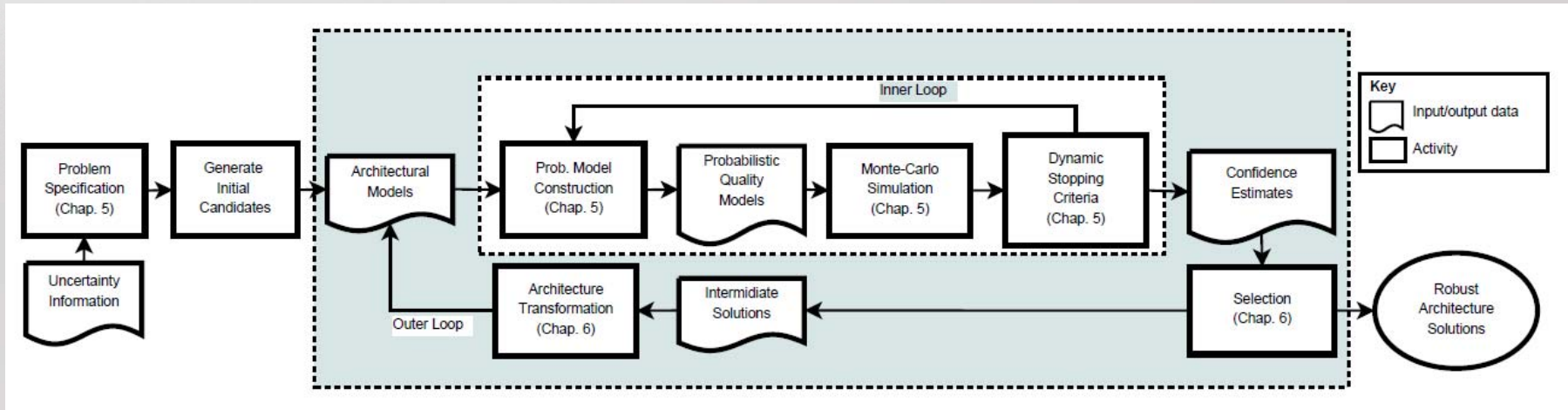



Architecture Evaluation under Uncertainty

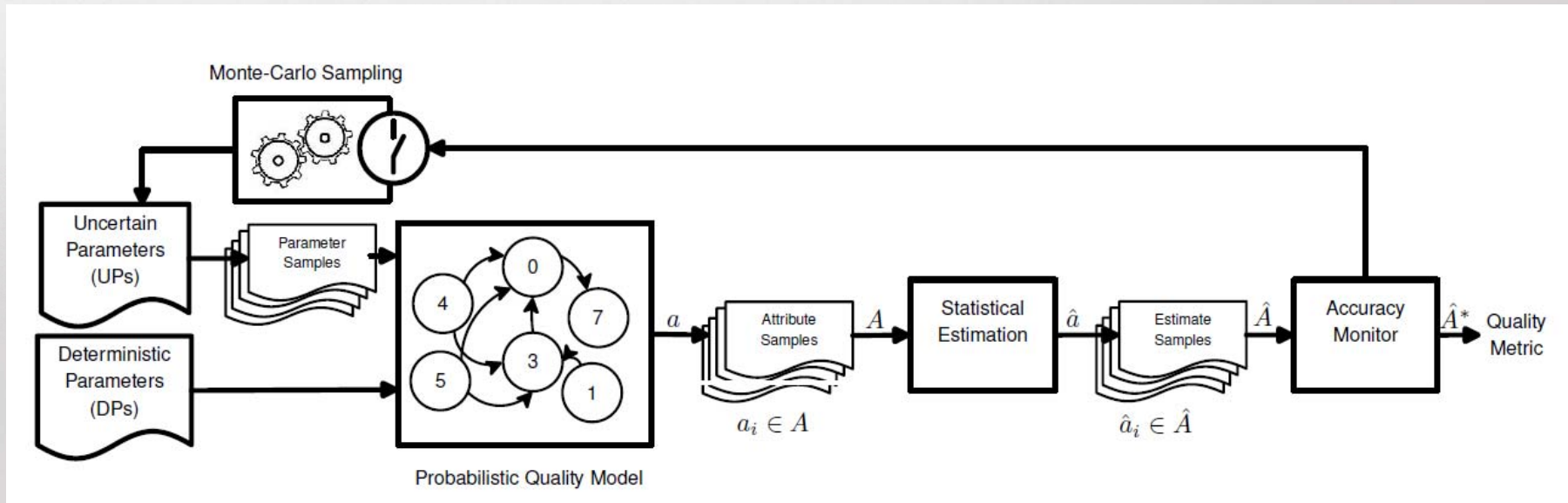



ArcheOpterix Framework

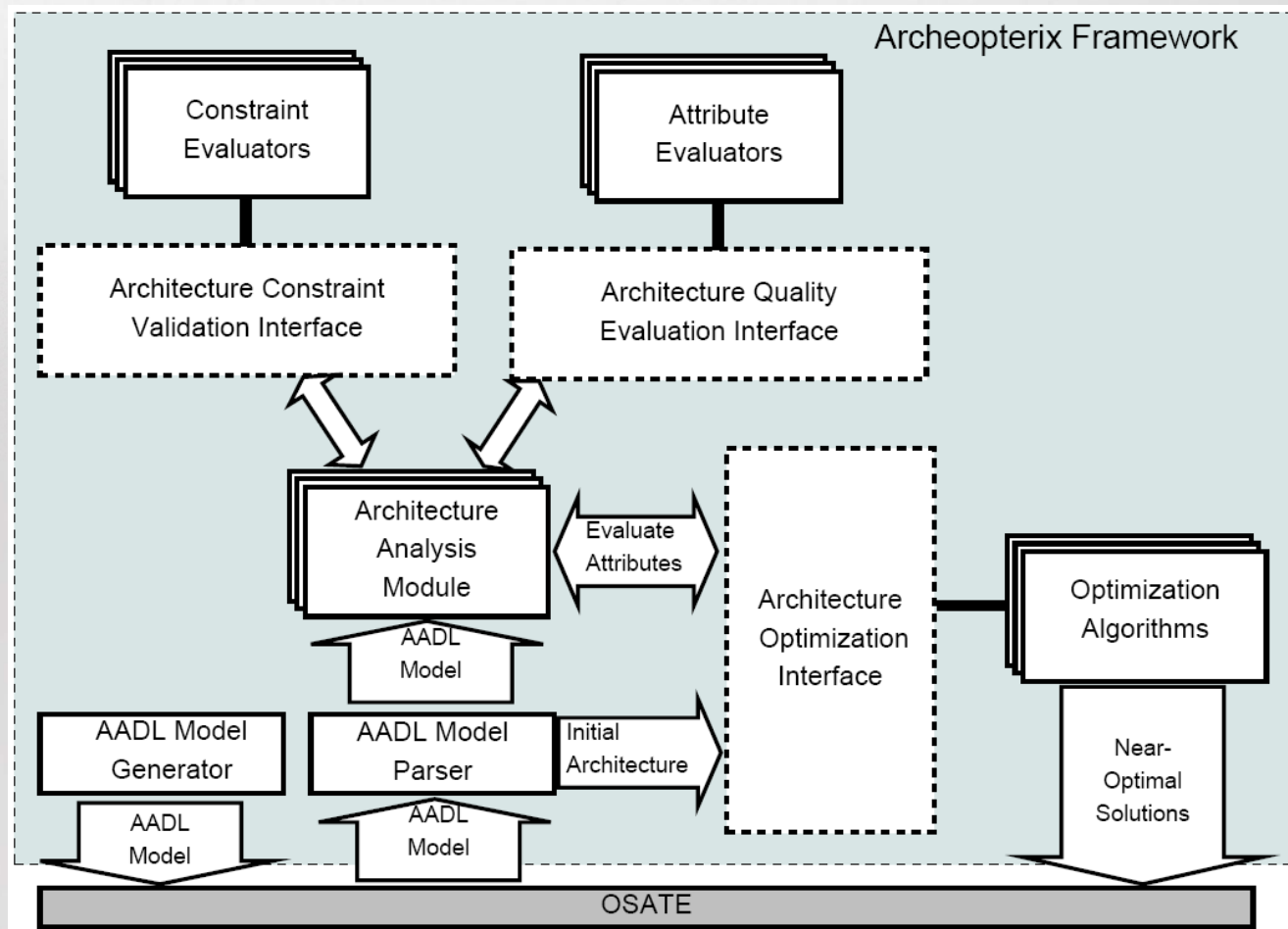



Example

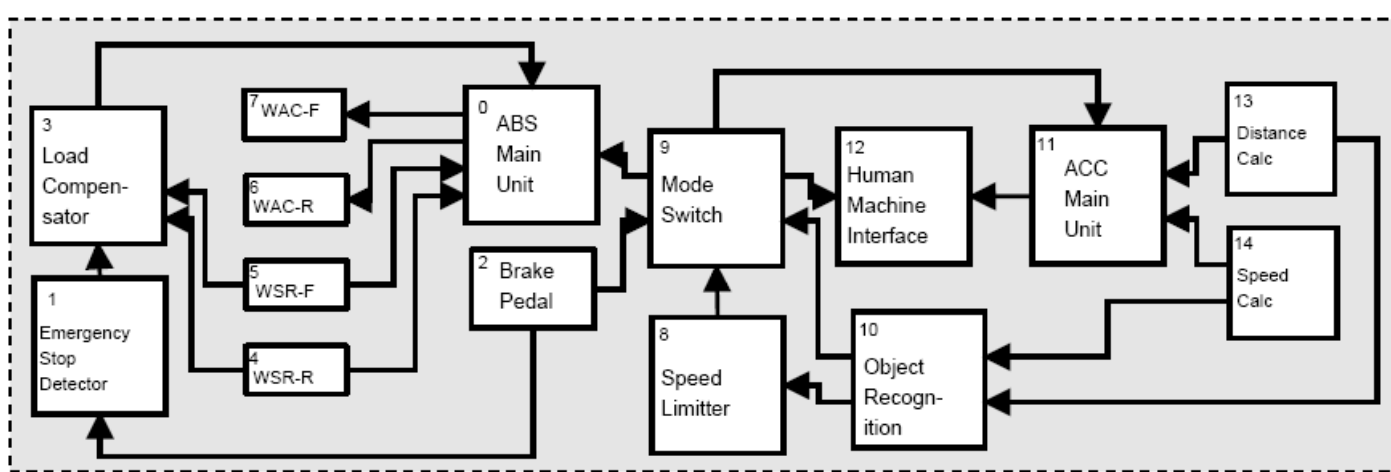

WAC : Wheel Actuator Controllers (Front and Rear)
WSR : Wheel Sensor Readers (Front and Rear)

(a) SW Architecture

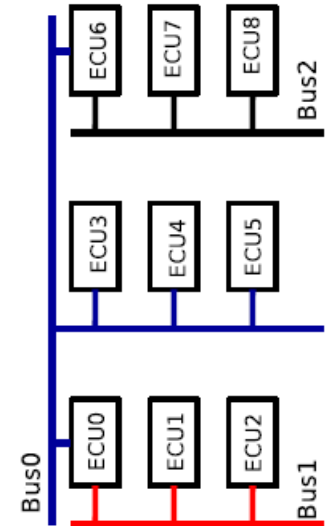

(b) HW Arch.



Robust Optimization Results

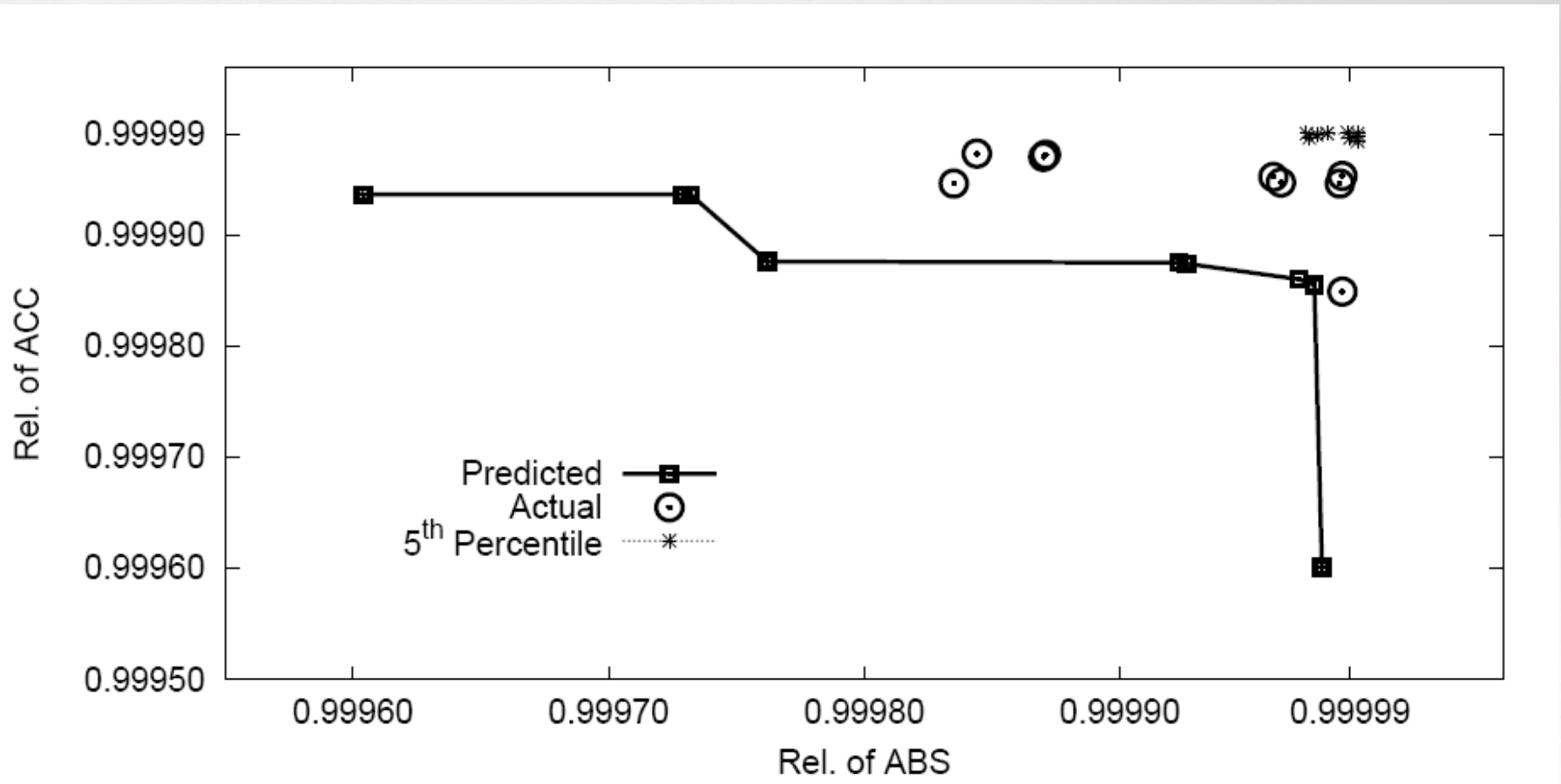



Publications

2011

- Indika Meedeniya, Irene Moser, Aldeida Aleti and Lars Grunske. "Software Architecture Evaluation under Uncertainty". In International Conference on Quality of Software Architectures (QoSA' 2011), to appear [ERA Rank : A]
- Aldeida Aleti and Indika Meedeniya. "Component Deployment Optimisation with Bayesian Learning ". In International Conference on Component Based Software Engineering (CBSE 2011), to appear [ERA Rank : A]
- Indika Meedeniya, Barbora Bůhnová, Aldeida Aleti, and Lars Grunske. "[Reliability-Driven Deployment Optimization for Embedded Systems](#)". Journal of Systems and Software (JSS), Volume 84, Issue 5, May 2011, Pages 835-846 [ERA Rank : A]

2010

- Indika Meedeniya and Lars Grunske. "[An efficient method for architecture-based reliability evaluation for evolving systems with changing parameters](#)". In International Symposium on Software Reliability Engineering, (ISSRE 2010), San Jose, CA, USA, November 1-4, 2010
- Indika Meedeniya, Barbora Bůhnová, Aldeida Aleti, and Lars Grunske. "[Architecture-driven reliability and energy optimization for complex embedded systems](#)". In International Conference on the Quality of Software Architectures, (QoSA 2010), Prague, Czech Republic, June 23 - 25, 2010, volume 6093 of LNCS, pages 52–67. Springer, 2010. [ERA Rank : A]
- Indika Meedeniya, "[An incremental methodology for quantitative software architecture evaluation with probabilistic models](#)", in Proceedings of the 32nd ACM/IEEE International Conference on Software Engineering, Volume 2, ICSE 2010, Cape Town, South Africa, 1-8 May 2010. ACM 2010, ISBN 978-1-60558-719-6 [ERA Rank : A]

2009

- Indika Meedeniya, Aldeida Aleti and Barbora Zimmerová, "[Redundancy Allocation in Automotive Systems using Multi-objective Optimisation](#)", in Symposium on Automotive/Avionics Systems Engineering (SAASE 2009), San Diego, CA, USA, October 13-16, 2009.
- Aldeida Aleti, Lars Grunske, Indika Meedeniya, and Irene Moser, "[Let the ants deploy your software - A hybrid ACO/GA based deployment optimisation strategy](#)", in 24th IEEE/ACM International Conference on Automated Software Engineering (ASE 2009), Auckland, New Zealand, November 16-20, 2009. IEEE Computer Society 2009, ISBN 978-0-7695-3891-4 [ERA Rank : A]
- Aldeida Aleti, Stefan Björnander, Lars Grunske, and Indika Meedeniya, "[ArcheOpterix: An extendable tool for architecture optimization of AADL models](#)," in ICSE 2009 Workshop on Model-Based Methodologies for Pervasive and Embedded Software (MOMPES 2009), May 16, 2009, Vancouver, Canada. IEEE Computer Society 2009, ISBN 978-1-4244-3721-4 .



Thank you !