



# Co-operative Research Centre for Advanced Automotive Technology

TECHNOLOGY, CHOICES AND BEHAVIOUR

AUTOCRC & SAE-A ELECTRIC VEHICLES SEMINAR

G. White 12 APRIL 2011

# Civilisation Priorities

◆ Civilisation is about mobility... And connection

- ◆ China - Great Wall
- ◆ Rome - Roads and viaducts
- ◆ Europe - Canals
- ◆ USA - Railroads



◆ Civilisations thrive on superior communications and mobility

# What are the next steps in mobility

## ◆ Civilisation is about mobility and connection....

- ◆ Connection demand can be at the expense of physical needs
- ◆ Developing country mobile phone uptake > individual affordability
- ◆ Social connectivity at expense of food?



# Connectivity Growth

- ◆ Internet
- ◆ Mobile phone usage
- ◆ Sensors (surveillance)
- ◆ Address growth exponential

OECD Broadband subscribers per 100 inhabitants, by technology, June 2009

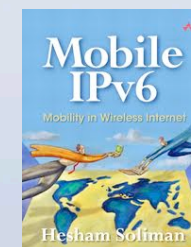
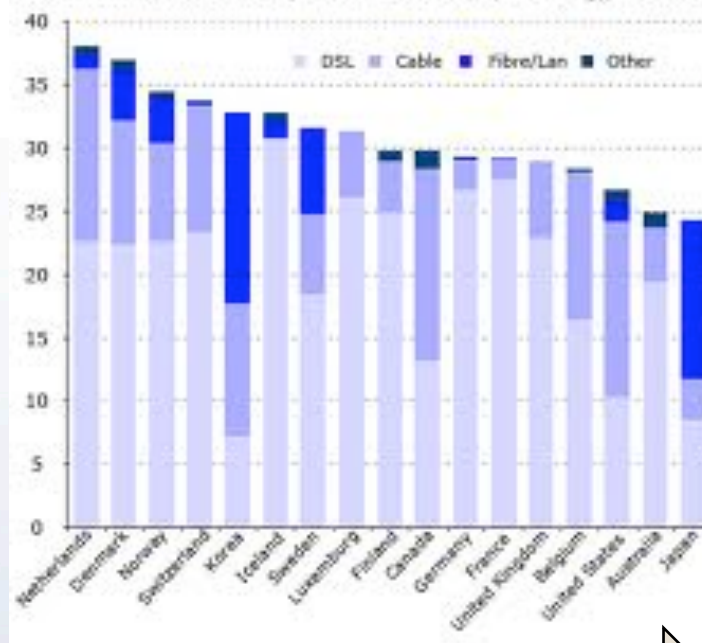

# Connectivity Growth

- ◆ Ultra short product life cycle (PLC) for mobility systems
  - ◆ Services (Apps), handsets, etc
  - ◆ Incompatible with automotive product cycle (months vs years)
  - ◆ Infrastructure struggles to keep pace



# Semi-mobile connectivity

◆ Established - connectivity around multiple user locations

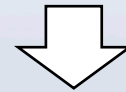

Demanded!



Result - dependence on the "Internet of Things"

# Consumer Needs

- ◆ Consumer need is driving the system growth
  - ◆ Convenience is King
  - ◆ Driving “back-office intelligence”

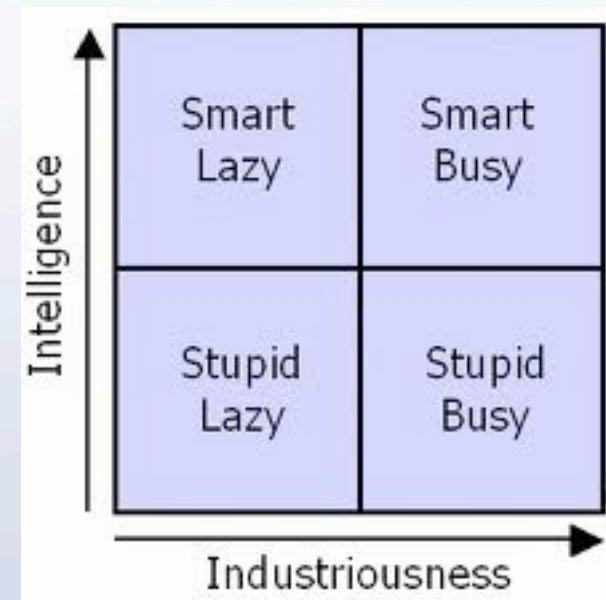

# Mobile Phone is Medium, Message & Mode

- ◆ Momentum continually gaining
- ◆ “Smart Phones rule!”



# Multiple Visions Converging

- ◆ Telephony, data, networking, infrastructure together
  - ◆ If we can build it, we will build an internet of things...



Yahoo



Nokia



Sony

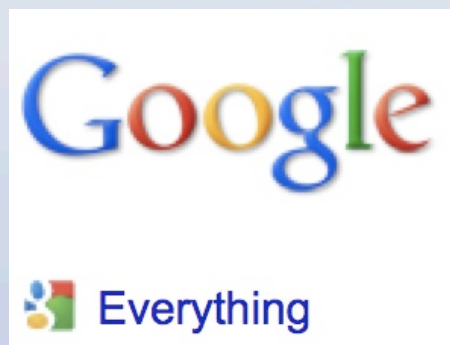

Paradise?

# Consumer Behavior / Culture

- ◆ Consumer behavior can be “regressive”
  - ◆ Opportunities to improve culture - evolve, educate
  - ◆ Technology is not the solution!
  - ◆ Enforcement is not the solution!



# What about Mobility Congestion?

- ◆ Social network and mobility are civilisation priorities, but the resulting congestion.....

Consumes:

- ◆ Time
- ◆ Energy
- ◆ Resources
- ◆ Productivity
- ◆ Health

And Produces:

- ◆ Pollution
- ◆ Heat
- ◆ Societal harm



# Cooperative ITS

- ◆ Short range wireless communication for mobility
  - ◆ “DSRC”
  - ◆ IEEE 802.11p @ 5.9GHz
  - ◆ Opens up a feature-rich conduit
  - ◆ Already use 5.8GHz for E-Tag tolling

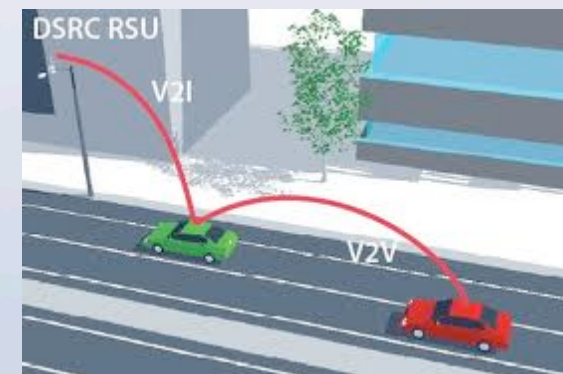
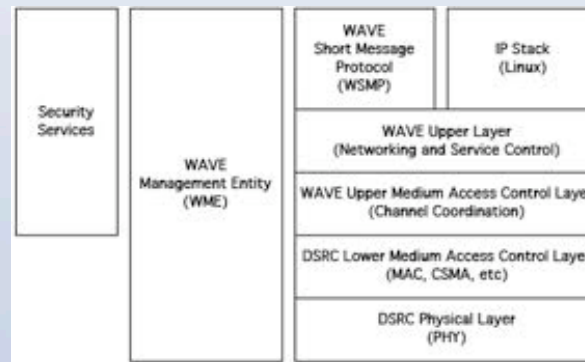
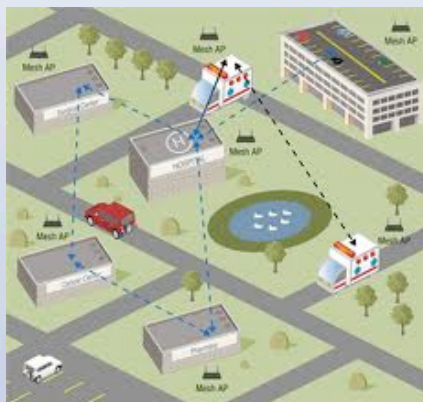
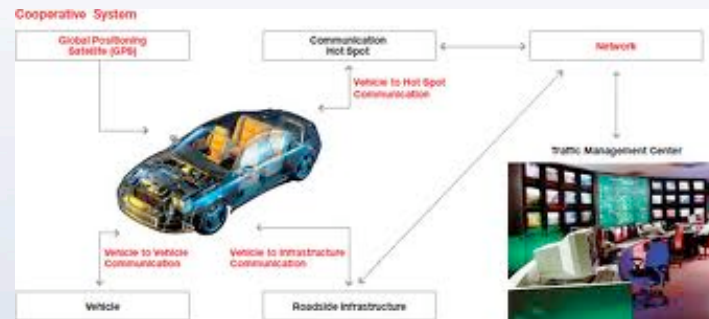
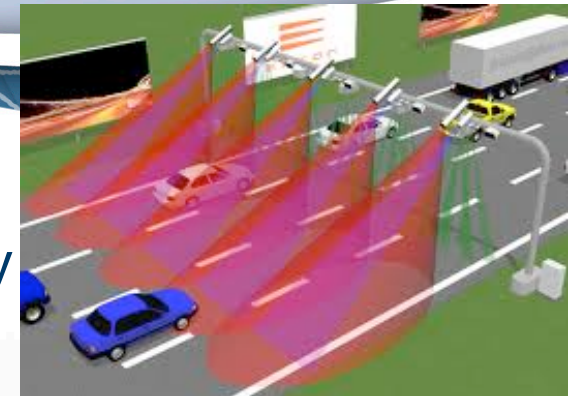

## Its all about the Energy

### Energy Consumers:

- ◀ Demand is monotonic increasing
- ◀ Concentrated demand from major city centres in developed countries
- ◀ Driven by demand for convenience and comfort >> unreasonable?
- ◀ High levels of unnecessary energy consumption
- ◀ Inefficient real-world energy conversion, esp. transport

### Energy Supply:

- ◀ Largely fossil fuel based
- ◀ Expanding renewable & nuclear energy supply base - lagging behind
- ◀ Capacity matched to peak demand - waste
- ◀ Cloud over nuclear take-up following Fukushima accident
- ◀ Potential for energy shortages in near term

# Its all about the Energy

- ◆ Massive investment in energy stewardship
- ◆ Replacing Brown with Green
- ◆ The grid is rapidly becoming SMART
- ◆ On-going debate on green mobility

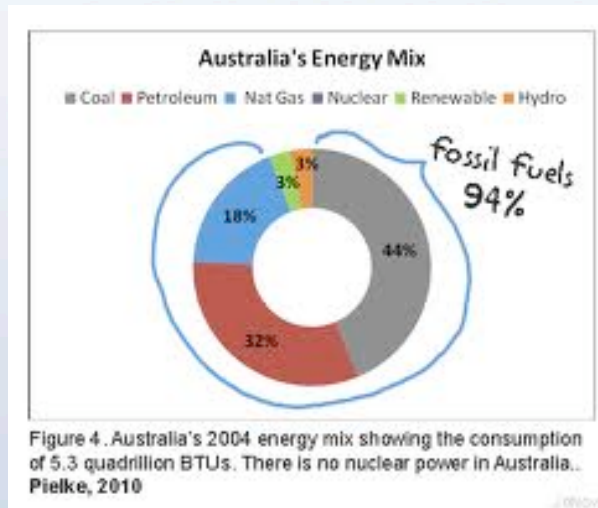

## Are EVs the Answer?

Using an Electric Vehicle CAN give many benefits to all - the car becomes a “good environmental citizen”:

- ◆ A convenient, vast refueling infrastructure across the country - any power point.
- ◆ A true choice of energy, including zero-emissions electricity in all states through billing systems
- ◆ Ability to eliminate energy waste when “idling” in traffic.
- ◆ Ability to store regenerated energy for future use, further reducing energy waste.
- ◆ The ability to coordinate transport energy needs with grid capacity, improving grid efficiency and further reducing greenhouse emissions.



# Can EVs Do More for Mobility?

Integrating the Electric Vehicle with a connected mobility system CAN support safety and congestion initiatives:

- ◆ EVs have enhanced communications systems
- ◆ Opportunity to link EV on-board telematics with intelligent transport systems.
- ◆ Link with mass transit systems.
- ◆ Influence driver behaviour?
- ◆ Potential to:  
*Integrate and achieve the two “vision zero” challenges: vehicle emissions and road casualties*



# Mobility Modes

◆ How do we integrate and support ALL our mobility modes?



## Who is working on the problems?

### Problems:

- ◆ Cost of congestion in Australia - \$9.4Bn in 2007, forecast \$18+Bn by 2020.
- ◆ Cost of road injuries/fatalities - \$10Bn p.a.(1463 fatalities in 2008).
- ◆ Roads transport contributes 14% of Australian greenhouse emissions, congestion causes about half of this.
- ◆ Cost of incremental unnecessary energy consumption

### Investigators:

- ◆ Concerned Safety, Transport and ICT researchers
- ◆ Loosely formed research collaborations
- ◆ Federal and State Road Authorities
- ◆ Energy, fuel economy and climate change associations
- ◆ Research consortia AutoCRC, NICTA

## What is the opinion so far?

*“We cannot build our way out of the congestion and safety problem”*

### Options:

- ◆ Explore Intelligent Transport Systems as one solution.
- ◆ Use DSRC technology facilitate deployment of ITS.
- ◆ Apply Connected Mobility concepts
- ◆ Take an energy-stewardship perspective

### Benefits:

- ◆ Reduce road fatalities by up to 33%.
- ◆ Address social issues of congestion, productivity
- ◆ Address environmental issues of energy, greenhouse emissions.
- ◆ Cross-industry benefits - health, mining, agriculture.

## A Centre for Connected Mobility?

- ◆ An organic sector-wide development centre serving Australian connected mobility needs
  - ◆ Australian collaboration opportunity
  - ◆ International linkage and technology transfer
  - ◆ Industry linkages - creating products, services, infrastructure solutions
  - ◆ Government and industry policy informing
  - ◆ Demonstrations, development for commercialisation
  - ◆ Research
  - ◆ Education

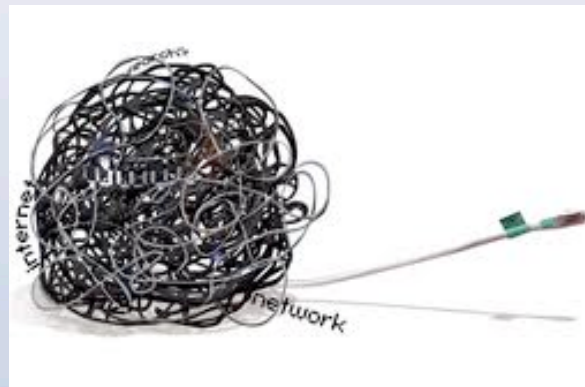

Thank You