



www.csiro.au

EV Drivetrains

Dr Howard C Lovatt
Stream Leader – Scientific Devices
22nd April 2010



Outline

- **Topologies**
 - Conventional
 - Fixed Ratio
 - Per-wheel
 - In-wheel
- **Motor Types**
 - Induction/AC
 - Permanent Magnet (PM)
 - Interior Permanent Magnet (IPM)
 - Switched Reluctance (SR)
- **Motor Controllers**
 - AC, PM, IPM, & SR
- **AutoCRC Visionary EV Drivetrain**
 - Participants
 - Vision
 - Realization

Topologies

Conventional

Fixed Ratio

Per-wheel

In-wheel

Conventional



Front Wheel Drive Typ.

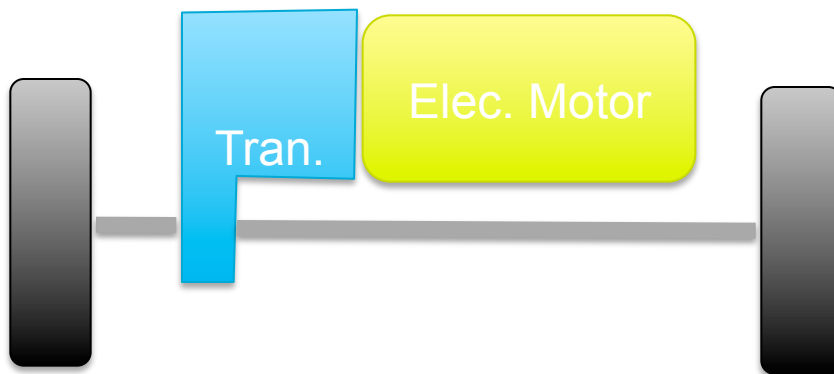

Blade EV Crash Test

Fixed Ratio



Front Wheel Drive Typ.

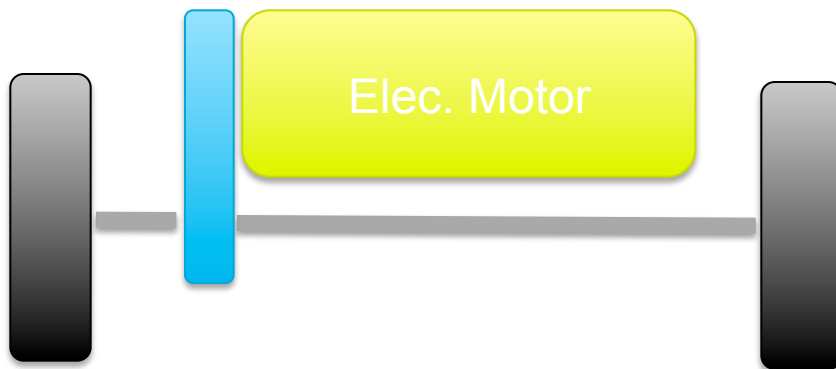

Nissan Leaf EV

Per-wheel

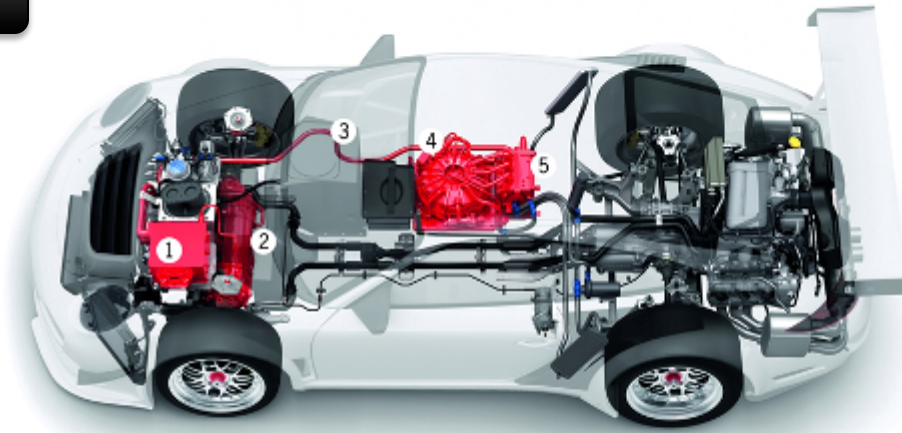
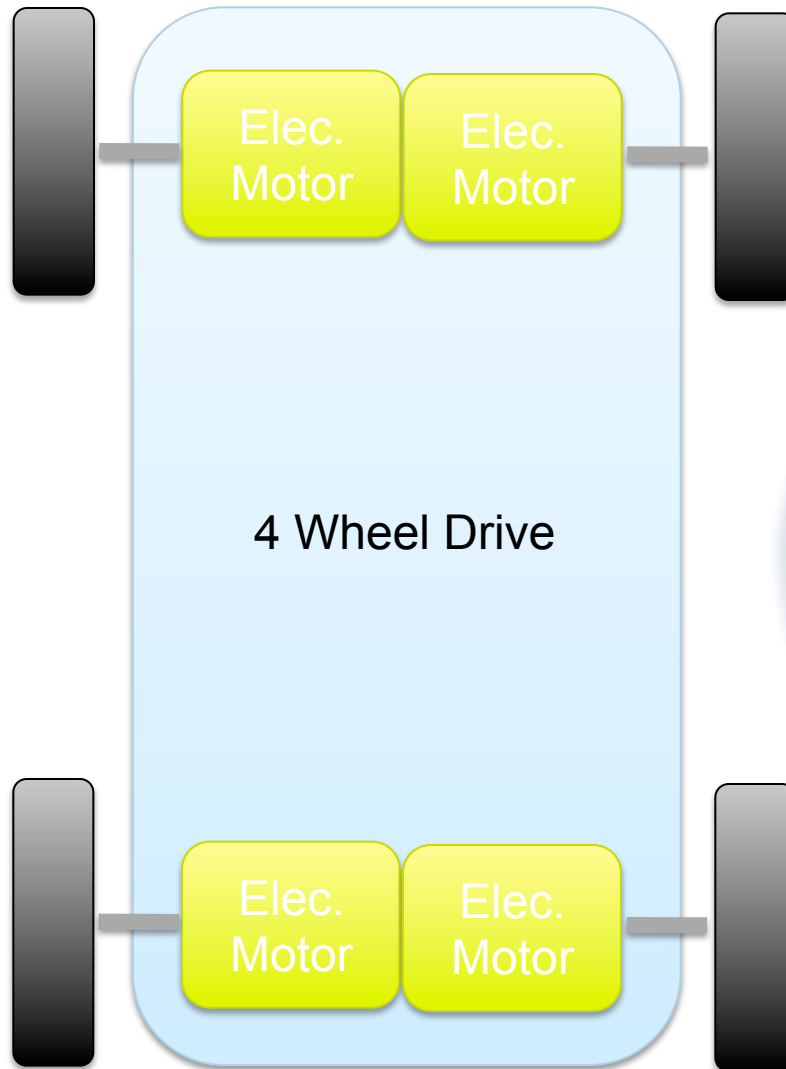

Porsche Hybrid

In-wheel

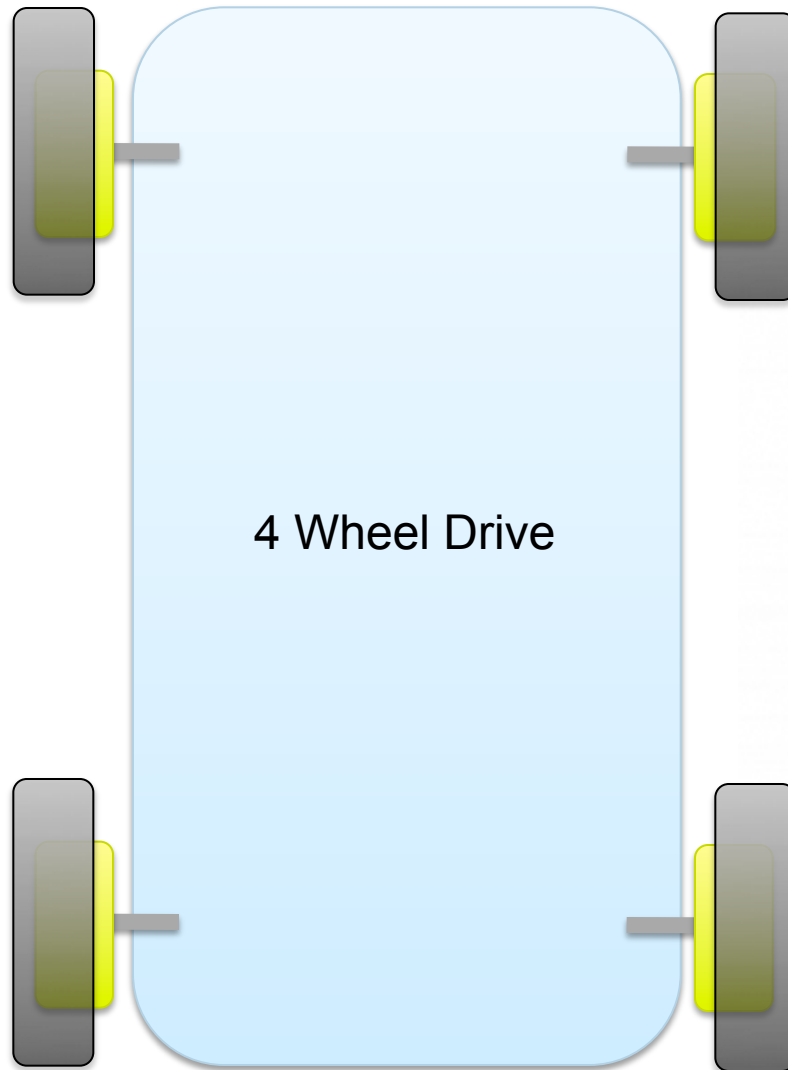

Michelin Active Wheel System

Motor Types

Induction/AC

Permanent Magnet (PM)

Interior Permanent Magnet (IPM)

Switched Reluctance (SR)

Induction/AC

Construction

www.automatedbuildings.com

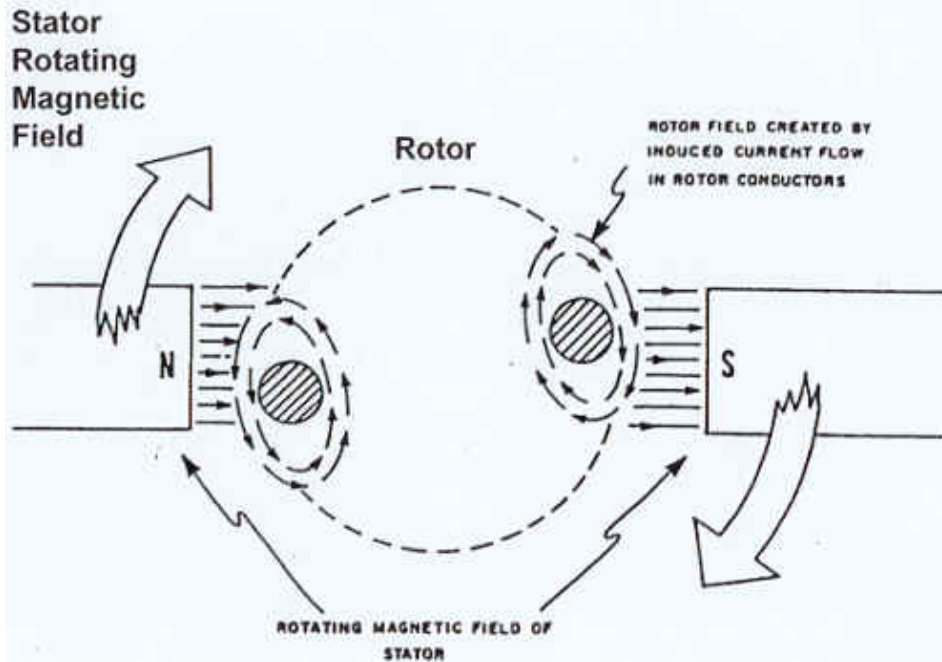
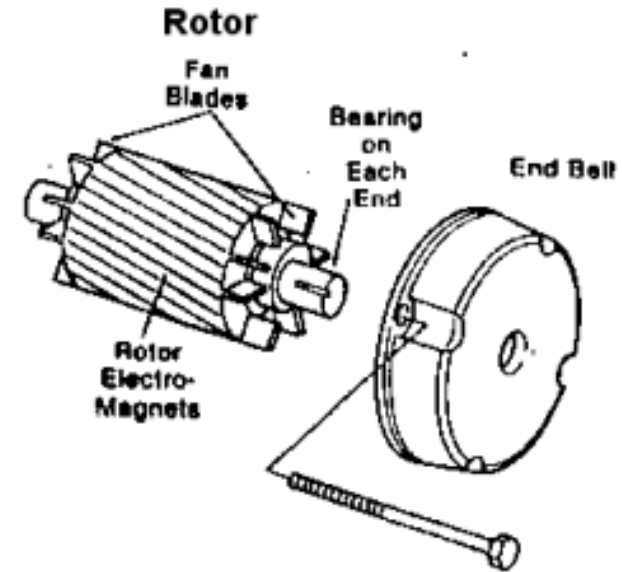
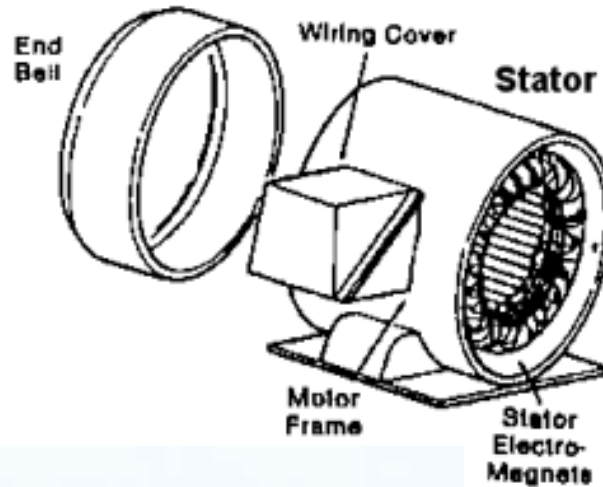

How It Works

www.automatedbuildings.com

Permanent Magnet (PM)

Field-oriented control at work

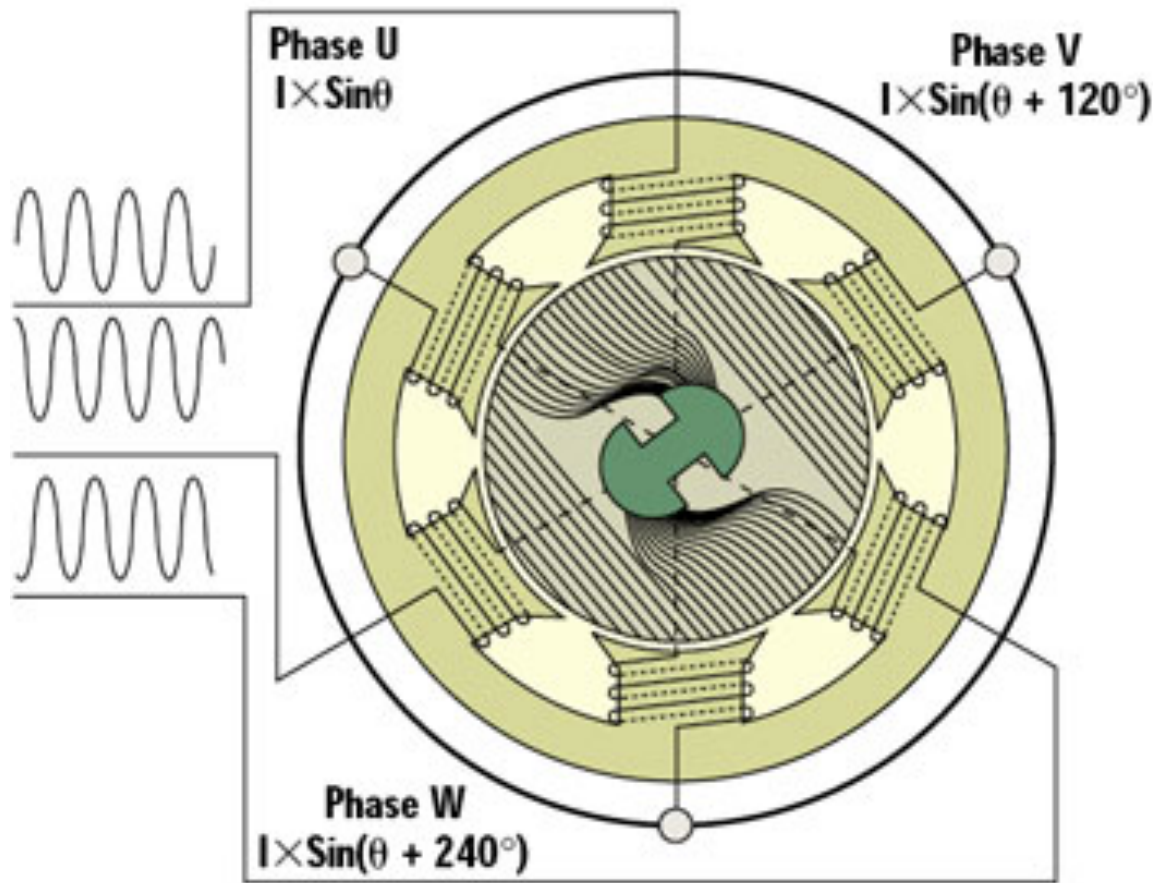

machinedesign.com

Interior Permanent Magnet (IPM)

 MagNet *Plug-in* for  PSIM

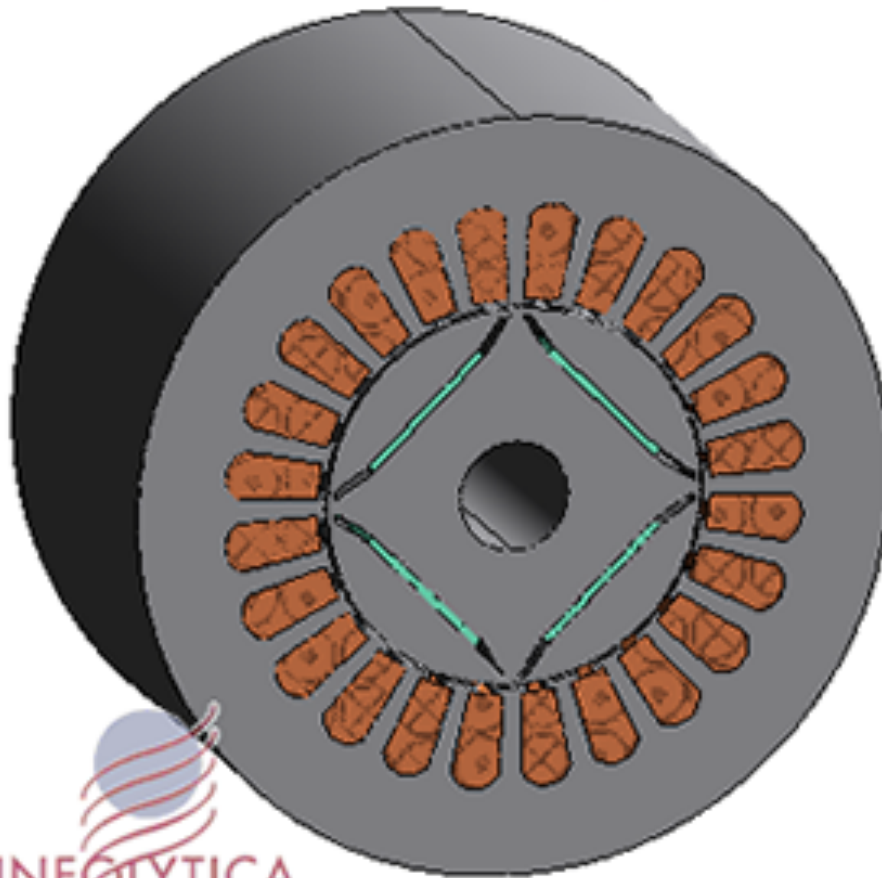

Switched Reluctance (SR)

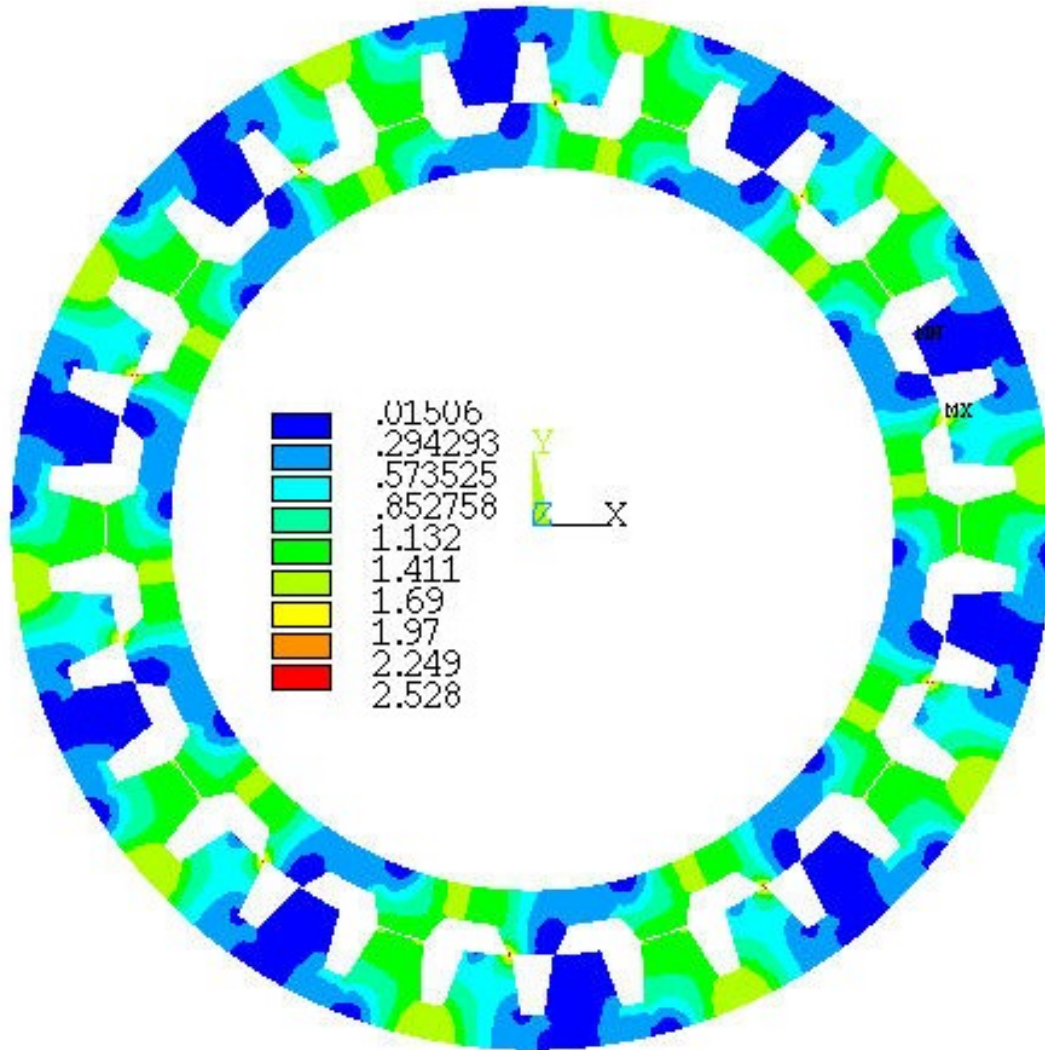

Motor Controllers

AC, PM, IPM, & SR

AC, PM, & IPM

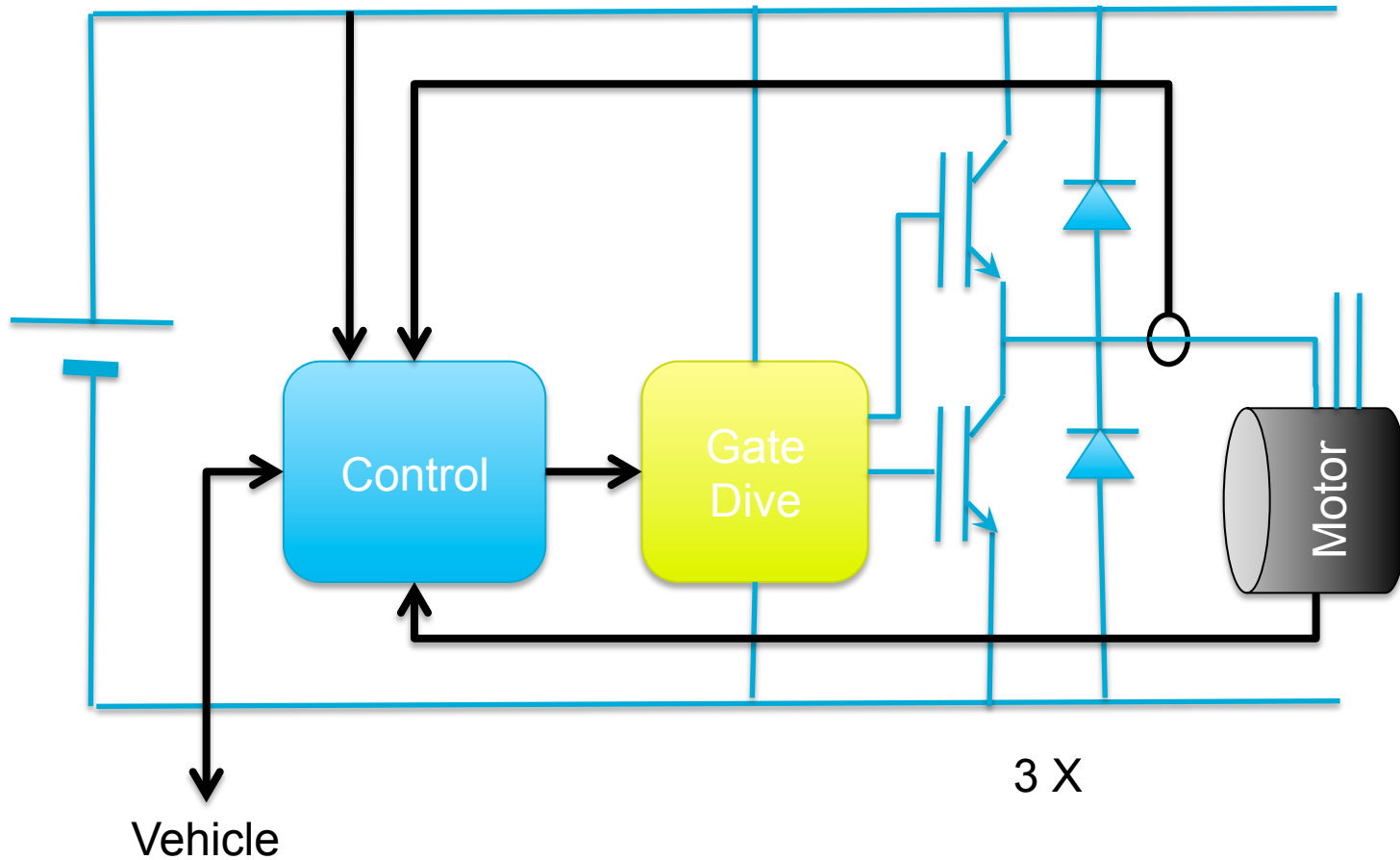

AutoCRC Visionary EV Drivetrain

Participants

Vision

Realization

Participants



Vision

- Enable original EV manufacture in Australia
 - Whole of vehicle including body
- Enable EV conversion industry in Australia
 - Convert an existing IC engine vehicle
- Advance the state of the art
 - More advanced than drivetrains going into production now

In-wheel

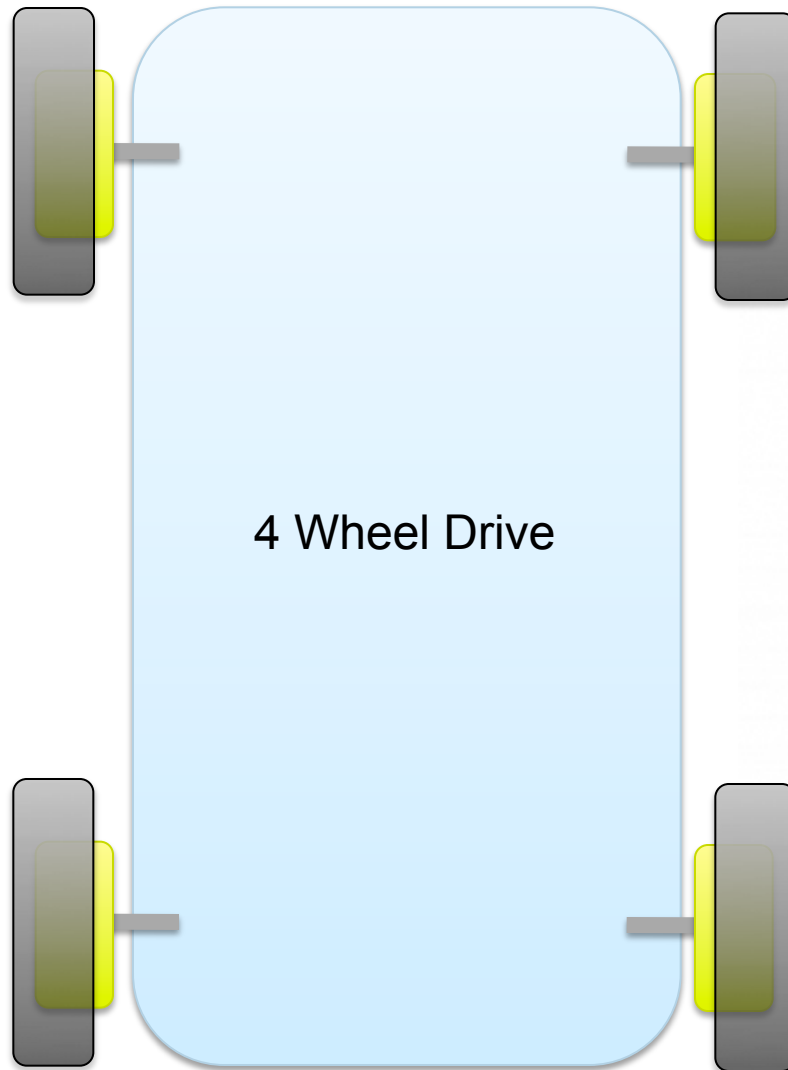

Michelin Active Wheel System

Solar Race Car

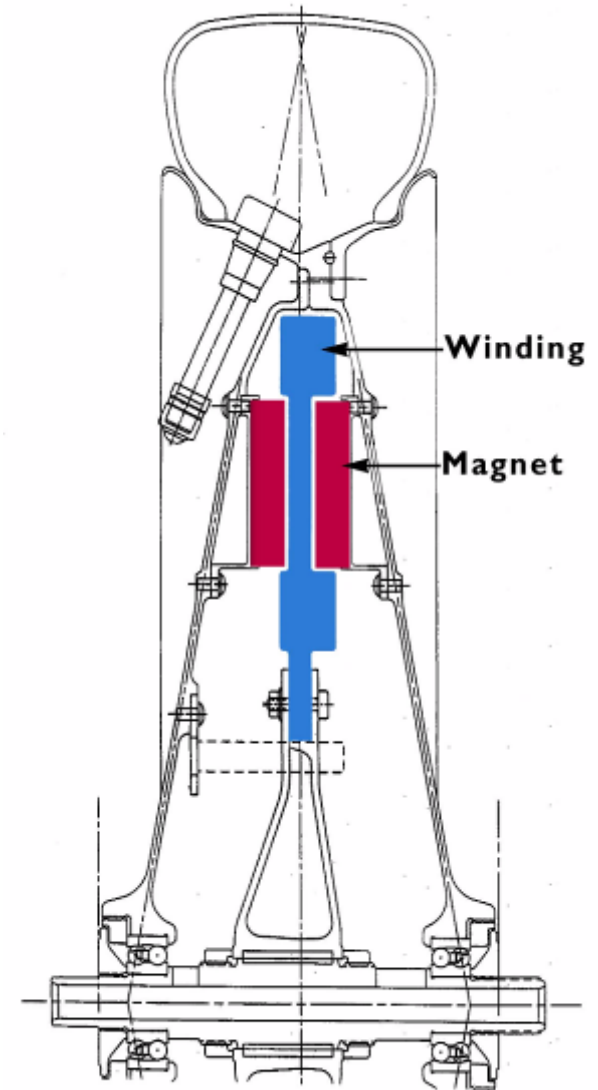
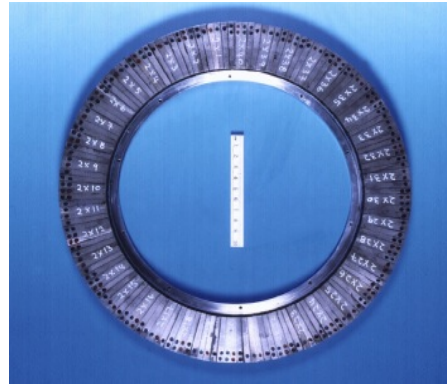

Realization

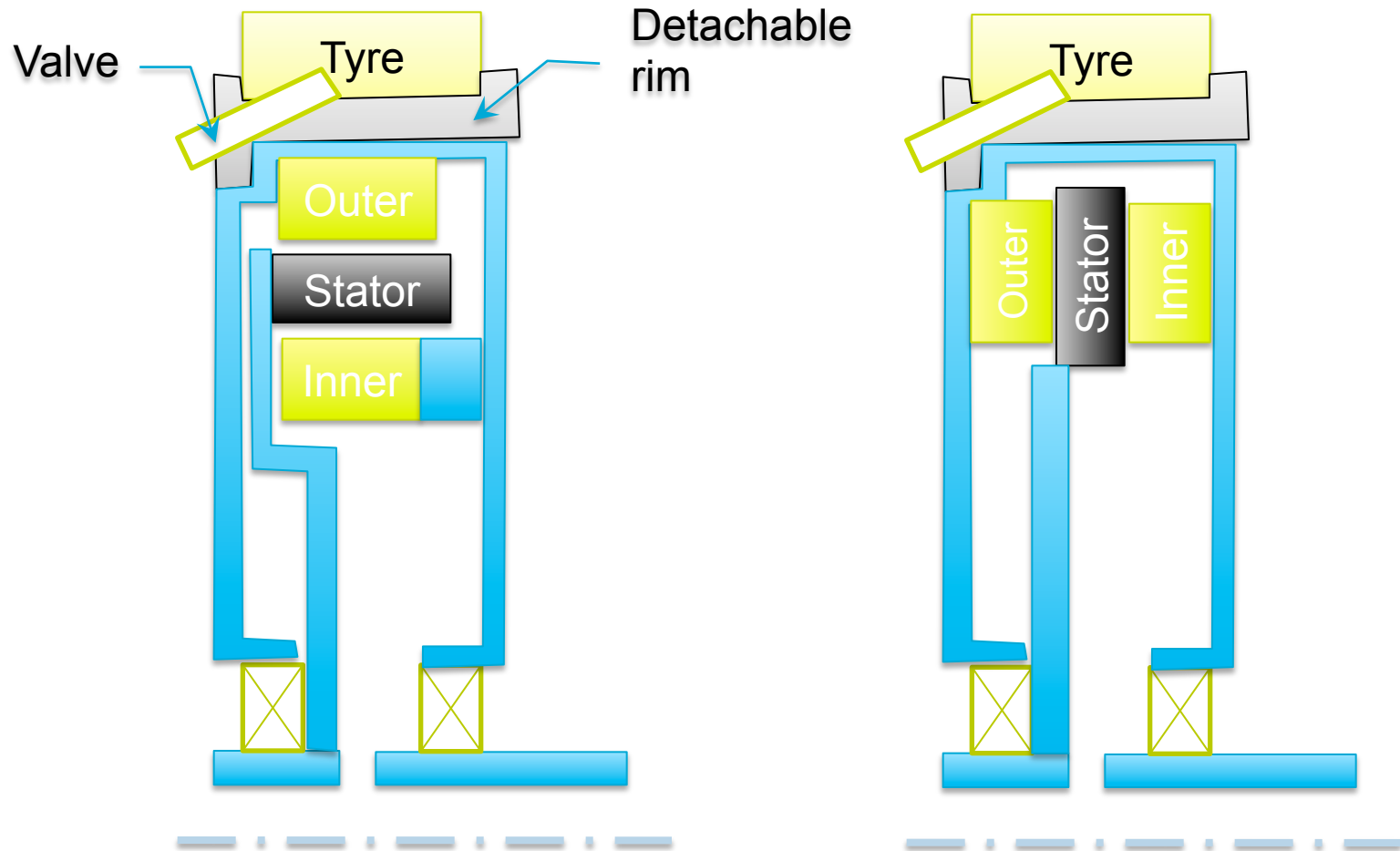

Summary

- **Topologies**
 - Conventional
 - Fixed Ratio
 - Per-wheel
 - In-wheel
- **Motor Types**
 - Induction/AC
 - Permanent Magnet (PM)
 - Interior Permanent Magnet (IPM)
 - Switched Reluctance (SR)
- **Motor Controllers**
 - AC, PM, & IPM
 - SR
- **AutoCRC Visionary EV Drivetrain**
 - Participants
 - Vision
 - Realization

CSIRO Material Science and Engineering (CMSE)

Dr. Howard C Lovatt

Stream Leader – Scientific Devices

Phone: +61 2 9413 7412

Email: howard.lovatt@csiro.au

Web: www.csiro.au/science/ElectricMachines.html

Thank You

Contact Us

Phone: 1300 363 400 or +61 3 9545 2176

Email: Enquiries@csiro.au **Web:** www.csiro.au



Bio

Dr. Lovatt is a Senior Scientist at CSIRO with interest in technology management, electrical machines, thermoelectrics, power electronics, control electronics, energy efficiency, waste heat recovery, energy harvesting, hybrid vehicles, electric vehicles, and solar car racing.

In the past he was technical lead for the CSIRO Hybrid Vehicle Project, which resulted in the ECOMmodore and aXcess LEV vehicles. For this work he won the CSIRO Chairman's Medal in 2001 (which is CSIRO's highest award).

He also one of the designers of The CSIRO/UTS Solar Car race motor that is used by most of the top solar race teams throughout the world.